

# Overvoltage protection at X.21 interface

D-SUB PIN No.	Signal	PT 5-HF-12DC & PT 2x2+F-BE		
		No. 1	No. 2	No. 3
1	Screen	Terminal 3	-	-
2	T_neg	Terminal 1	-	-
3	C_neg	Terminal 7	-	-
4	R_neg	-	Terminal 1	-
5	I_neg	-	Terminal 7	-
6	S_neg	-	-	Terminal 1
7	B_neg	-	-	Terminal 7
8	Ground	Terminal 9	1)	1)
9	T_pos	Terminal 5	-	-
10	C_pos	Terminal 11	-	-
11	R_pos	-	Terminal 5	-
12	I_pos	-	Terminal 11	-
13	S_pos	-	-	Terminal 5
14	B_pos	-	-	Terminal 11
15	Not connected	-	-	-

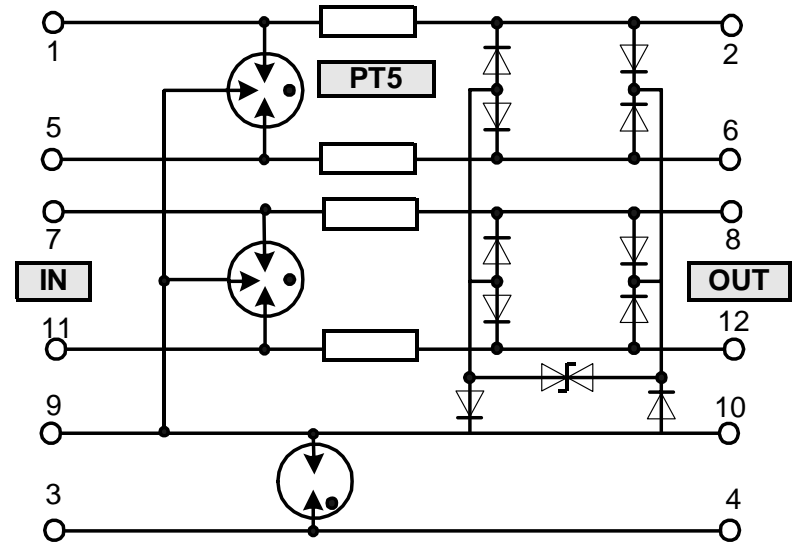

1) The ground of the PT 5-HF-12DC have to be connected together.